



- (Patent Pending)

Discovery High Wind 150 mph
Bolt Down Ground Mount - Existing Concrete

Light-Weight Solution For Any Terrain

The Discovery is a ballasted ground mount solution designed for commercial and utility scale installations. Benefits of the Discovery include minimal components for a fast installation, zero ground penetration, UL 467 integrated grounding, ability to easily move installations in the future, and a plate to adjust for any slope. The Discovery is the perfect solution for mounting solar installations into pre-existing concrete or attaching to pre-formed ballast blocks.

Starter Section

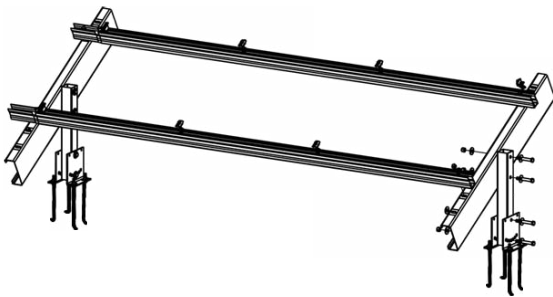

Add-On Section

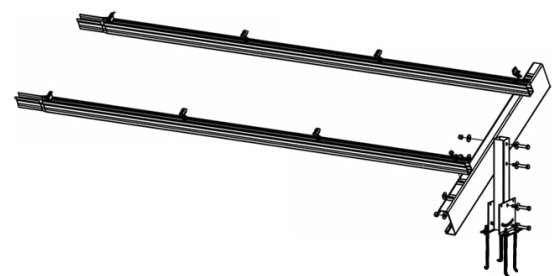

Rail Attachment

Key Features

- UL 467 grounding mid clamps
- Truss, Rails, Post, and Plates 100% galvanized
- Ideal for large commercial and utility scale installations
- Can be installed on un-even terrain
- Light-weight design Ideal for landfills & brown fields
- Five to forty degree tilt angles available.
- Accomodates all major panel sizes.
- Lower shipping costs.

"Your Single Solar Source"

Discovery High Wind 150 mph

Bolt Down Ground Mount - Existing Concrete

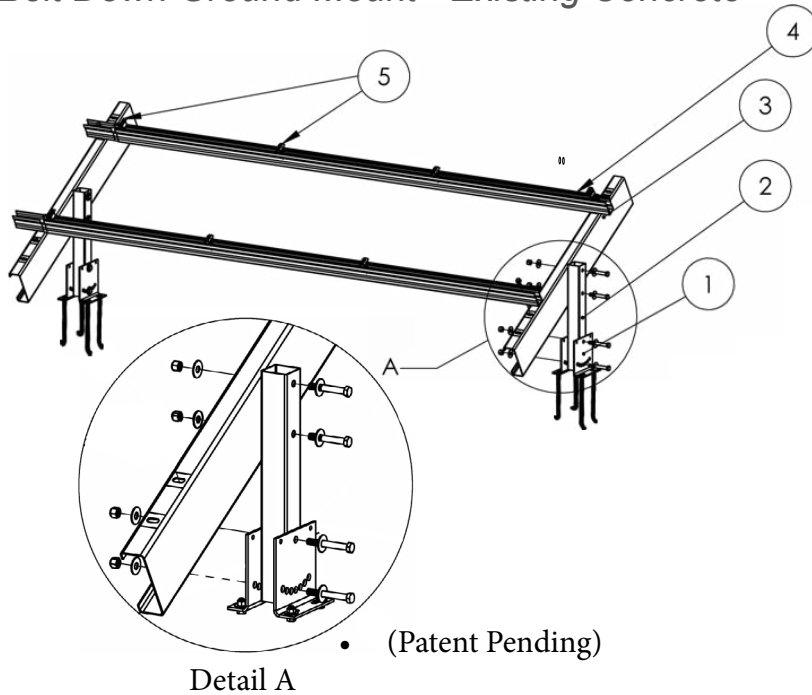

Technical Specifications

Application	Open Field Layout
Foundation	Pre-existing concrete
Module Orientation	Portrait
Module Compatibility	All Major Brands - 60 & 72 Cell Modules
Tilt Angle Available	5° - 40°
Ground Clearance	Standard - 24"
Grade of Terrain	NS = 20° / EW = 5°
Wind Load	Up to 150 MPH *
Snow Load	Up to 80 PSF *
Purlin Length	126"
Material Composition	Galvanized Steel G-90 - Post, Truss & Rails
Warranty	20 Years
Manufacturing	Made in USA

Major Components

1 Post Mounting Bracket

Pre-punched holes allow for tilt adjustment to follow land contours with 0° - 20° of adjustability

2 Adjustable Square Post

Multiple lengths available to meet various height clearances. Includes 1" increment holes for in field vertical adjustment.

3 Stamped Truss

Pre-punched truss design allows for faster connection to post.

4 Stamped Z-Purlin

Quick assembly with easy adjustment and convenient panel clip installation.

5 Mid & End Clamps

Mid clamps include integrated UL 467 grounding. Clamps are adjustable to accommodate all major module thicknesses from 30mm - 50 mm.

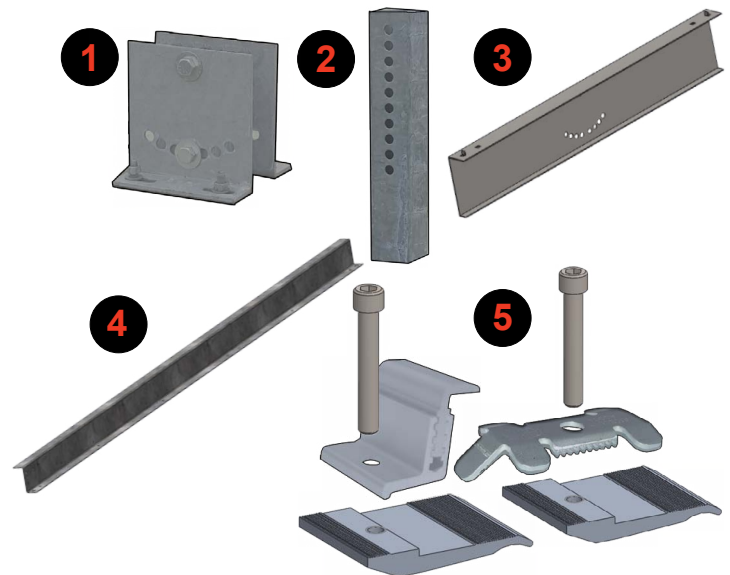

No.	Part	Starter Section	Add-On Section
1.	Plate, Ballasted Mount Adjust, Bent w/ Hilti Bolts	4 pcs	2 pcs
2.	Tube, 3" X 3" X 26"	2 pcs	1 pc
3.	52" C-Channel Stamped Truss	2 pcs	1 pc
4.	126", 11 GA, Z Purlin	2 pcs	2 pcs
5.	Assy, Mid & End Clamps	8 pcs	8 pcs
All assembly hardware included.			

*Snow loads are ground snow loads estimated at 40 deg.
*wind loads are estimated at 10 deg.
*Loading is single factor snow only or wind only.
*All specifications subject to change without notice.